

Bits en Chips Hardware conferentie 17 juni 2010

Chips: a Dutch delicacy or an infinite subsidy drain

Marcel Pelgrom

Bits+Chips columnist

NXP fellow-university relations

Point-One nano-electronics chair

IEEE Distinguished Lecturer

TU Delft, Uni Twente teacher

Stanford Uni Consulting professor



Alkmaar,	Eindhoven	Leiden	Sittard
Almelo	Enschede	Lent	Sneek
Amersfoort	Geldrop	Maarheeze	Stadskanaal
Amsterdam	Gorinchem	Margraten	Staphorst
Apeldoorn	Groningen	Middelburg	Terneuzen
Arnhem	Haalderen	Nieuwegein	Tilburg
Baarn	Heer	Nijmegen	Uden
Best	Heerlen	Nuenen	Utrecht
Blerick	Helden-Panningen	Olst	Valkenswaard
Breda	Helmond	Oosterhout	Veendam
Bunde	Hengelo	Oss	Veenendaal
Culemborg	Hilversum	Rijswijk	Veldhoven
Deurne	Hoogeveen	Roermond	Weert
Doetinchem	Hoorn	Roosendaal	Weesp
Dordrecht	Huizen	Schijndel	Winschoten
Drachten	Klazienaveen	s-Graveland	Winterswijk
Eijsden	Leeuwarden	s-Gravenhage	Zwolle

Bron: wikipedia

Alkmaar,
Almelo
Amersfoort
Amsterdam
Apeldoorn
Arnhem
Baarn
Best
Blerick
Breda
Bunde
Culemborg
Deurne
Doetinchem
Dordrecht
Drachten
Eijsden

Eindhoven

Leiden

Sittard



Leeuwarden

s-Gravenhage

Zwolle

Bron: wikipedia, by [driesvandanelzen](#)

30 years ago:

The Philips ecosystem delivered a solid framework for:

- Innovation (wide product scope, many technical disciplines)
- Personal development
- Infrastructure
- Internal education and career path
- Strong interactions with universities, HBO etc.

Today:

Many independent companies:

- ASML
- ASM Int.
- NXP
- Atos origin
- Broadcom
- ST-Ericsson
- Axiom, Bruco,
- Besi
- etc.

Where is the 2010 eco system for the next round of innovation?

Electronics innovation is the basis of the knowledge economy

Data for 2007 (GDP is \$ 48,900B)

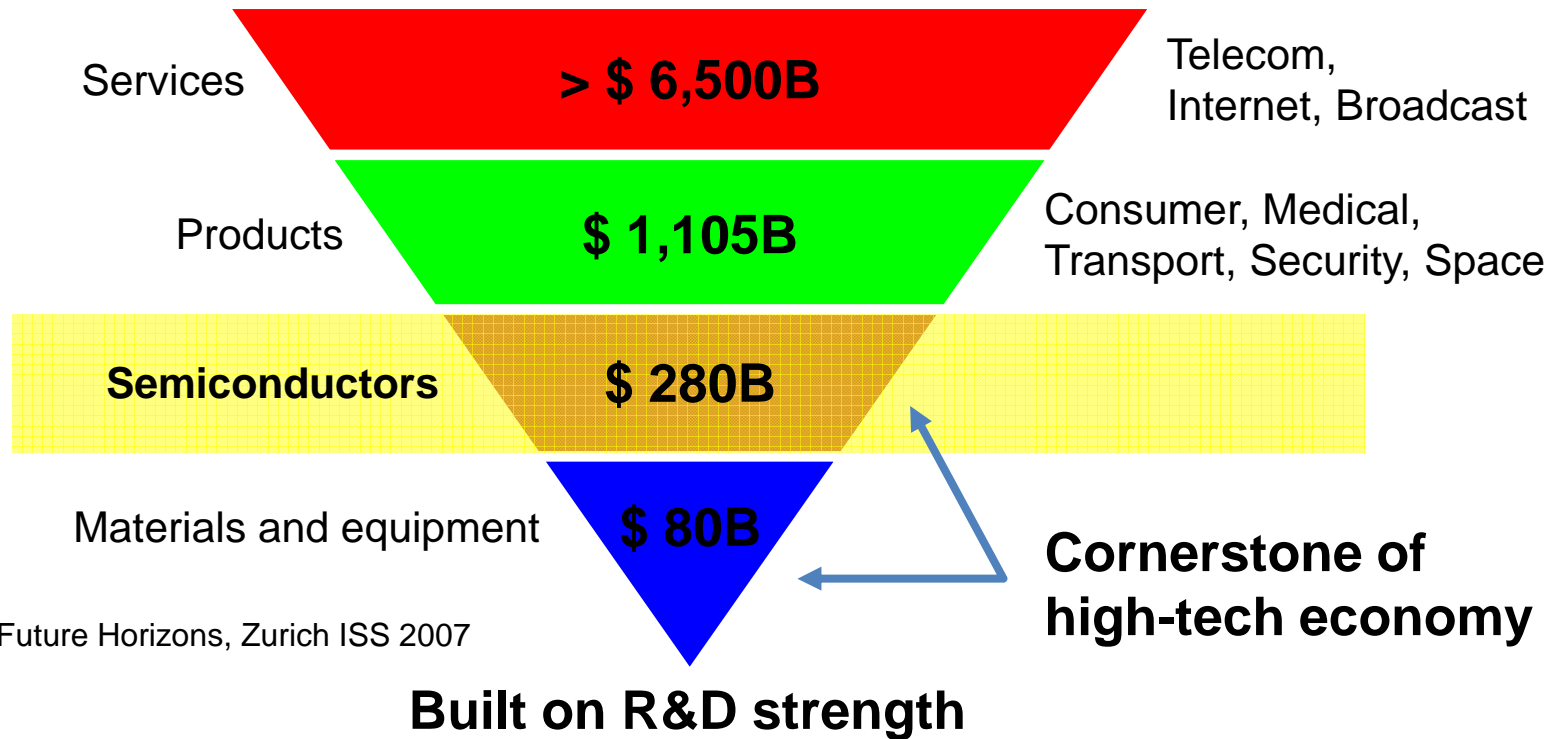

Source: Future Horizons, Zurich ISS 2007

CBS: Dutch companies account for 20 BE

And R&D is getting more expensive...

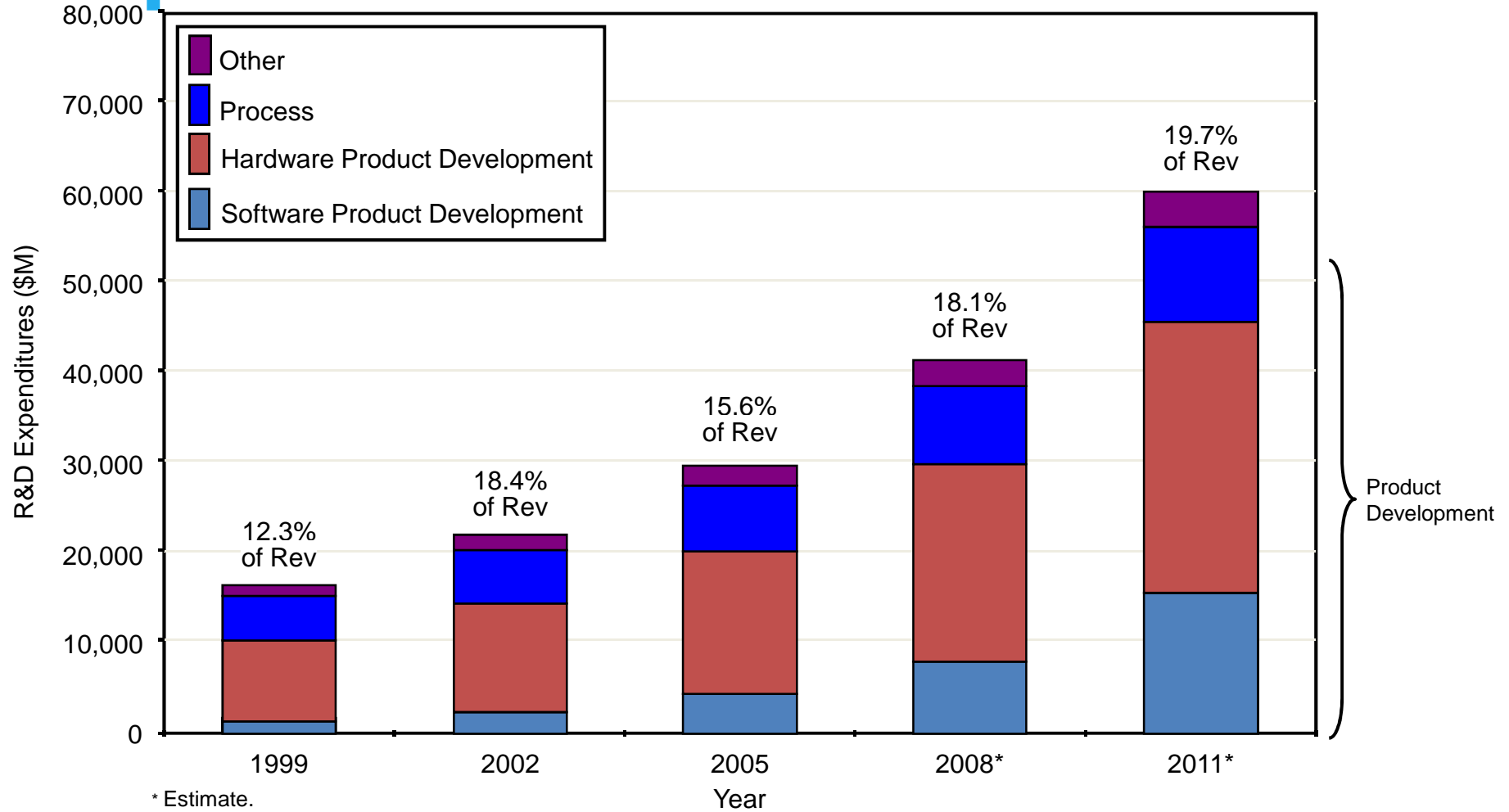

High-tech industry: from business



Moore's law

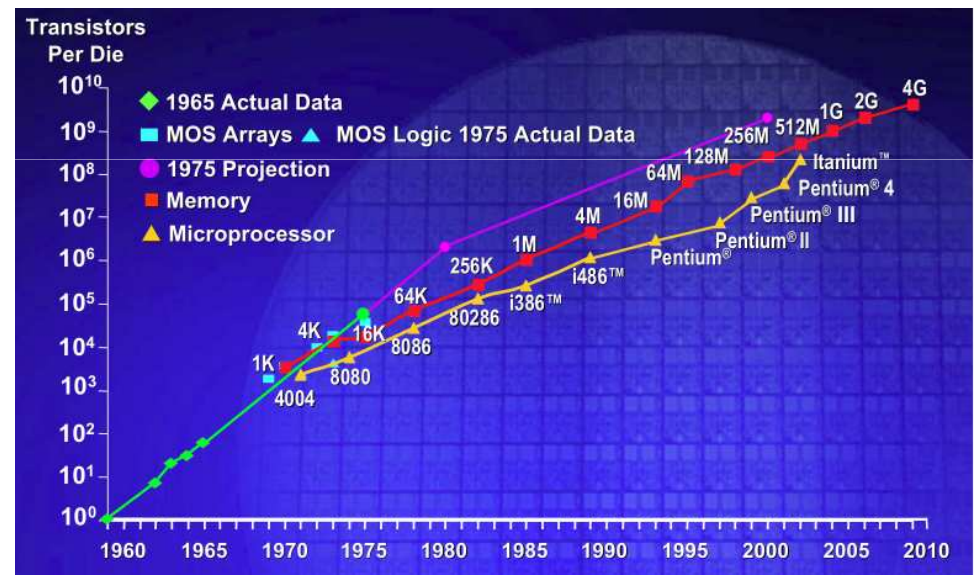

Source: Intel Corporation

.... to consumer driven ...



.... to society driven

Health & wellness



Transport & mobility



Security & safety



Energy & environment



Communication



E-society

Netherlands invests in R&D

Nr	Company	City	M€	FTE
1	Philips	Eindhoven	703	4581
2	ASML	Veldhoven	459	2350
3	Schering-Plough	Oss	400	1600
4	Shell	Amsterdam	373	1505
5	NXP	Eindhoven/ Nijmegen	310	1500
6	DSM	Geleen / Delft	241	1460
7	Oce	Venlo	164	920
8	Unilever	Vlaardingen	144	910
9	KPN	Leidschendam	125	2600
10	Thales	Hengelo	73	878

Dutch electronics



Bron: Technisch Weekblad, April 11, 200

Dutch innovation

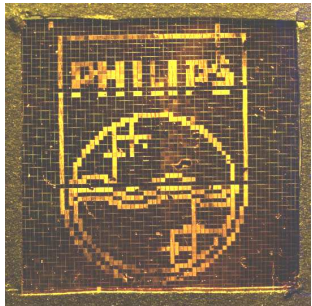
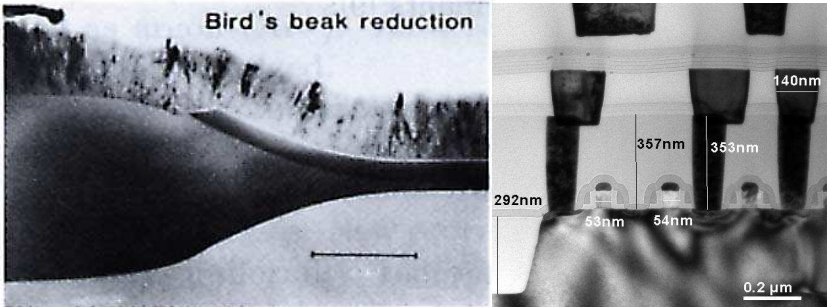

What is Point-One?

- An innovative Dutch hightech ecosysteem
- The first and largest Dutch innovation program.
- A union of industry and insitutes with 'N-E-M' R&D in the Netherlands.
 - nano-elestronics,
embedded systems,
mechatronics
- Aims at improving the Dutch competitive postion. Realise a growth of 10 BE in 2014.

Point-One System definition

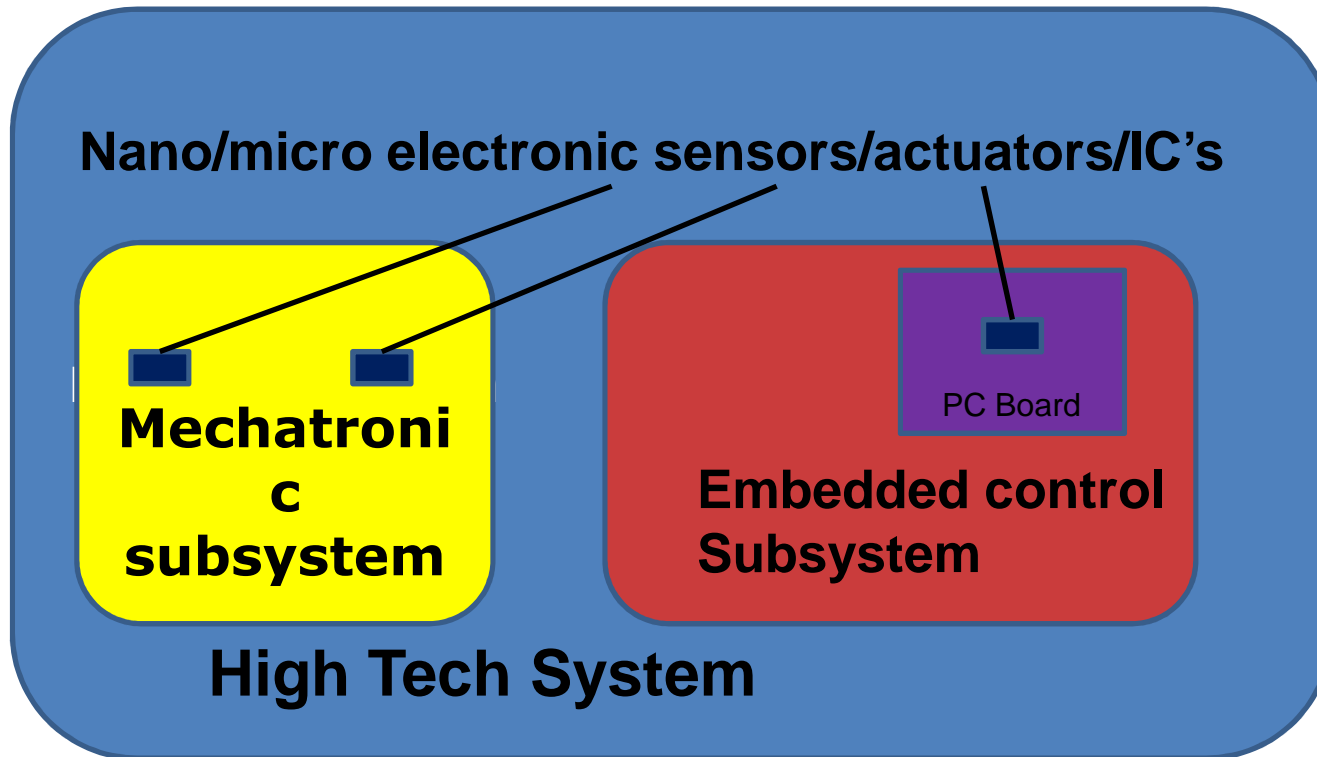

Point-One

Actions:

Internationale R&D subsidy €50M /year

National subsidy R&D €14

Improve SME position

Human capital

University-Industry program

3 working groups for creating a network

Workshops for match making and subsidy support

Pre-competitive mutual support in the working groups



Technology subsidy 2006-2009

1. Embedded systems	M€ 54,3	20%
2. Mechatronica	M€ 74,5	27%
3. Nanoelectronics	M€ 30,5	11%
4. Communication technology	M€ 12,4	5%
5. Imaging (Medical)	M€ 57,5	21%
6. Inkjet technology	M€ 21,3	8%
7. Materiaal technology	M€ 5,6	2%
8. Sensor technology	M€ 16,6	6%
9. Software	M€ 3,1	1%

	M€ 275,9	

(Other subsidy programs for energy, transport, sw etc.)

Bron: Ministerie van EZ, studie O. v. Batenburg

Market subsidy

1. Healthcare and wellbeing	M€ 50,0	18%
2. Energy and power	M€ 8,5	3%
3. ICT		
3.1. SC front-end equipment	M€ 76,9	28%
3.2. SC back-end equipment	M€ 13,8	5%
3.3. SC design and architecture	M€ 30,0	11%
3.4. Industrial printing	M€ 22,9	8%
4. Lifestyle and leisure	M€ 24,8	9%
5. Transport/logistics	M€ 38,7	14%
6. Security	M€ 3,2	1%
7. Manufacturing	M€ 2,8	1%
8. not specified	M€ 4,2	2%

	M€ 275,9	

Bron: Ministerie van EZ, studie O. v. Batenburg

TM combinaties (in Meuro)

<i>Point-One, 110 projects</i>	Meuro											Total (in technologies)
MARKET	1. Healthcare & wellbeing	2. Energy and power	3.1. SC front-end equipment	3.2. SC back-end equipment	3.3. SC design & architecture	3.4. Industrial printing	4. Lifestyle & leisure	5. Transport/ logistics	6. Security	7. Manufacturing	8. not specified	
TECHNOLOGY	1. Embedded Systems	2. Mechatronics	3. Nanoelectronics	4. Communication techn.	5. Imaging	6. Inkjet techn.	7. Material techn.	8. Sensor techn.	9. Software	Total (in markets)		
	0,17	3,56		4,56	7,13		2,49	30,80	1,43	0,67	3,53	54,34
	3,79		52,33	2,00	14,10					2,00	0,31	74,53
	0,45	0,28	20,57	7,26	1,58		0,06	0,31				30,51
		0,09			6,54		5,62				0,10	12,35
	42,85						10,82	2,06	1,70	0,06		57,49
						21,31						21,31
			4,04			1,63						5,67
	2,69	4,54					3,79	5,21	0,10	0,09	0,21	16,63
	0,07				0,63		2,00	0,34			0,03	3,07
	50,02	8,47	76,94	13,82	29,98	22,94	24,78	38,72	3,23	2,82	4,18	275,90

Bron: Ministerie van EZ, studie O. v. Batenburg

And many opportunities ahead

Sensors+actuators: principles and applications.

Communication: co-habitation and spectrum?

Vision: what should our computer see?

TeraHertz: a new field of application of just a me-too idea?

High performance mixed signal design

Pervasive Systems

Nano technologies



Conclusions

- The high-tech industry is rapidly changing from large company structures into a fragmented picture.
- Creates flexibility, but loses some necessary assets for staying ahead.
- Point-One is an initiative to remedy some issues and re vitalize Dutch innovation.
- Many opportunities to participate.